



INSTALLATION GUIDE

Harley-Davidson
Big Twins

Doc ID: 191-7115005
Revision: 040824

Table of Contents

OVERVIEW	3
TOOLS.....	3
INCLUDED PARTS	3
INSTALLATION TIPS	4
PREPARE BIKE FOR INSTALLATION.....	5
DISASSEMBLE CLUTCH.....	6
INSPECT THE BASKET.....	7
REMOVE THE CLUTCH HUB.....	7
INSTALL THE REKLUSE HUB	9
INSTALL THE BASKET SLEEVES	10
INSTALL THE CLUTCH PACK	11
INSTALL THE PRESSURE PLATE.....	11
INSTALL THE CLUTCH SPRINGS.....	12
Milwaukee 8 Models (17+)	12
Twin Cam Models (07-16).....	12
SET FREEPLAY (CABLE BIKES ONLY)	13
Collapsing the Cable on an M8	13
Collapsing the Cable on a Twin Cam.....	14
Set The Adjuster Screw	14
Resetting Cable Freeplay on an M8.....	16
Resetting Cable Freeplay on a TwinCam	16
INSTALL THE PRIMARY COVER.....	17
BREAK IN THE NEW CLUTCH.....	18
MAINTENANCE.....	18
Disk inspection examples.....	19
TROUBLESHOOTING	20
Clutch Drag	20
Clutch Slip	20
NEED ADDITIONAL HELP?.....	20

OVERVIEW

This kit replaces many of the OE (Original Equipment) or “stock” clutch parts. These parts are designed specifically for your motorcycle to ensure optimal performance. The following is a summary of what is replaced:

- OE clutch pack (frictions and drive plates)
- OE clutch hub
- OE pressure plate and springs

The Apex Clutch replaces the OE assist and slip clutch. Eliminating the assist and slip clutch provides better modulation and a superior clutch lever feel.

TOOLS

- Hex key set (SAE)
- T27 & T70 Torx bits
- Torque wrench (capable of 170 lb.ft)
- 10 mm, 1/2” & 1 3/16” sockets
- End wrenches (SAE)
- Hydraulic shop press
- Snap ring pliers (internal & external)

INCLUDED PARTS

Refer to the included **Parts Fiche** for a detail of the components. Visit www.rekluse.com/support for a full parts fiche illustration and part numbers.

INSTALLATION TIPS

- Read the separate included Safety Information document before operating the vehicle with the product installed.
- This kit is compatible **ONLY** with the OE or Rekluse clutch components.
- Read this entire document before performing any steps.
- If you install this product for a customer or another person, instruct them to read the **Safety Information** document and the **Installation Guide** before operating the bike with the product.
- Protect eyes and skin – wear safety glasses and work gloves.
- Use the torque values listed in the instructions. Otherwise, use the torque specifications found in your OE service manual.
- Different spring options may be available purchased from Rekluse (depending on the bike model) for:
 - Motorcycles with taller gearing or modified engines with increased horsepower
 - Customers looking for a lighter lever pull
- For optimal clutch performance, Rekluse recommends using fresh, clean oil that **meets JASO-MA** oil rating requirements. Rekluse offers Factory Formulated Oil™ developed specifically for Rekluse products. Rekluse Factory Formulated Oil is a perfect complement to any OEM or aftermarket wet clutch. Visit www.rekluse.com to learn more.

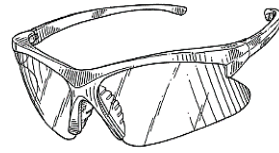

PREPARE BIKE FOR INSTALLATION

1. Stand the bike up on a lift or suitable bike stand.
2. Remove the oil drain plug and drain the oil into a suitable container.

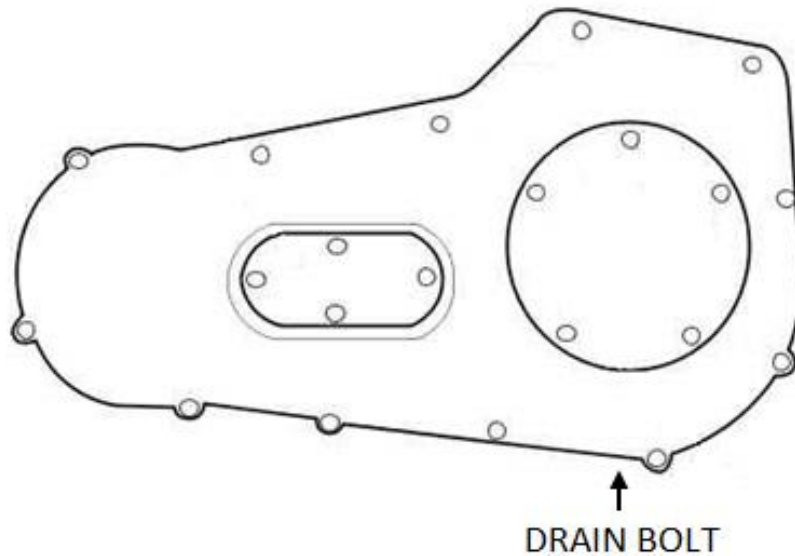

3. Remove any parts that are attached or blocking the primary chaincase cover. These may include the left floorboard, foot peg(s), shift lever, and/or the side stand.

Note: Before removing the shift lever, shift the bike into 5th gear.

4. Remove the primary chaincase cover.

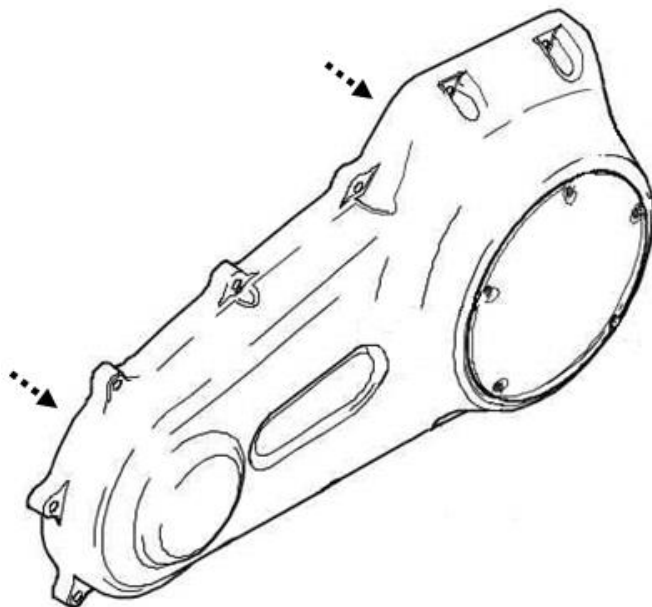

DISASSEMBLE CLUTCH

1. Soak the TorqDrive® friction disks in new primary chaincase oil for 5 minutes. Make sure the friction disks are coated on both sides.

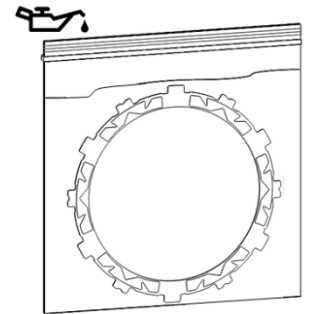

2. Remove the following OE parts. *You may need to use dental pick tools to reach and remove the bottom plates and damper (judder) spring/seat.*

Representative image, your clutch may appear different.

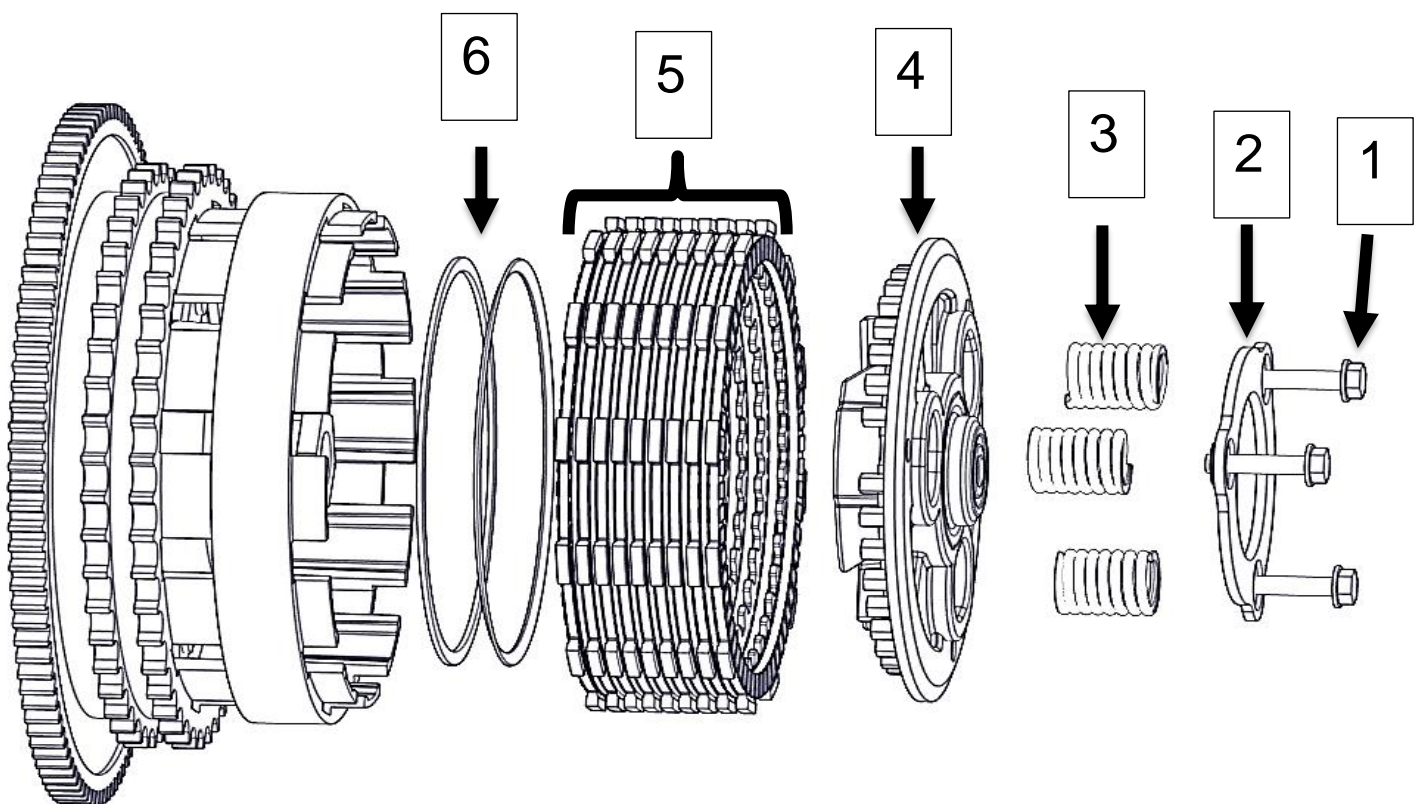

1	Pressure plate bolts
2	Spring hold-down ring
3	Pressure plate springs
4	Pressure plate
5	Clutch pack
6	Damper (judder) spring and seat

INSPECT THE BASKET

⚠ WARNING

Failure to inspect the basket and replace it if necessary could result in death, serious injury, and/or property damage.

Inspect the clutch basket for notching. Do not install sleeves or use products with a notched basket. Notched basket tang faces can cause the sleeves to break. Do not use baskets that have been filed, machined, or modified on the tangs. Replace the basket if necessary.

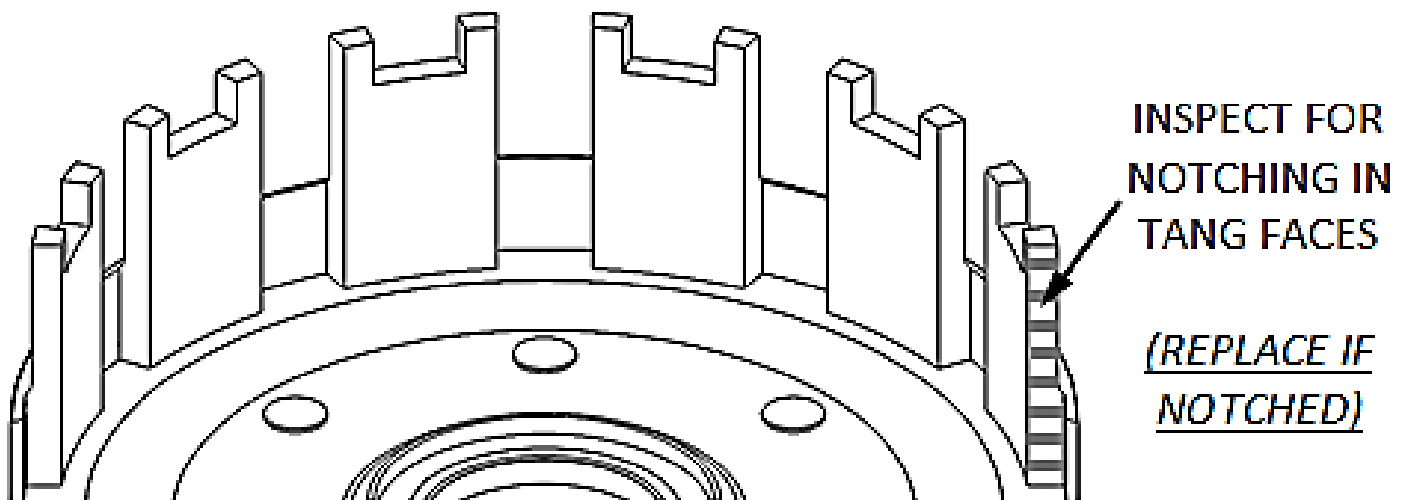

REMOVE THE CLUTCH HUB

1. Remove the **left-hand thread** center clutch nut

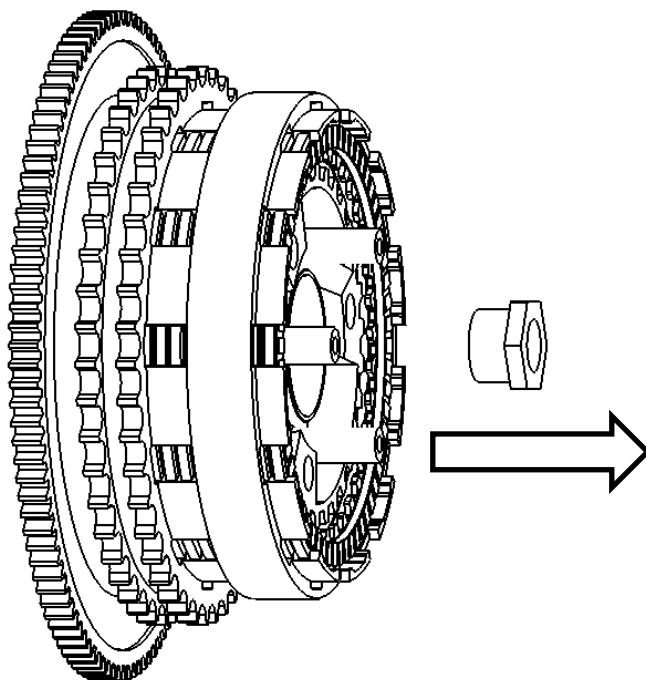

2. Remove the right-hand thread compensator bolt

Note: A brace between the compensator and clutch basket sprockets will be required to keep them from spinning.

3. Remove the chain tensioner

4. Remove the basket & hub assembly along with the primary chain and the compensator sprocket

5. Flip the basket assembly over and remove the smaller snap ring from the hub shaft

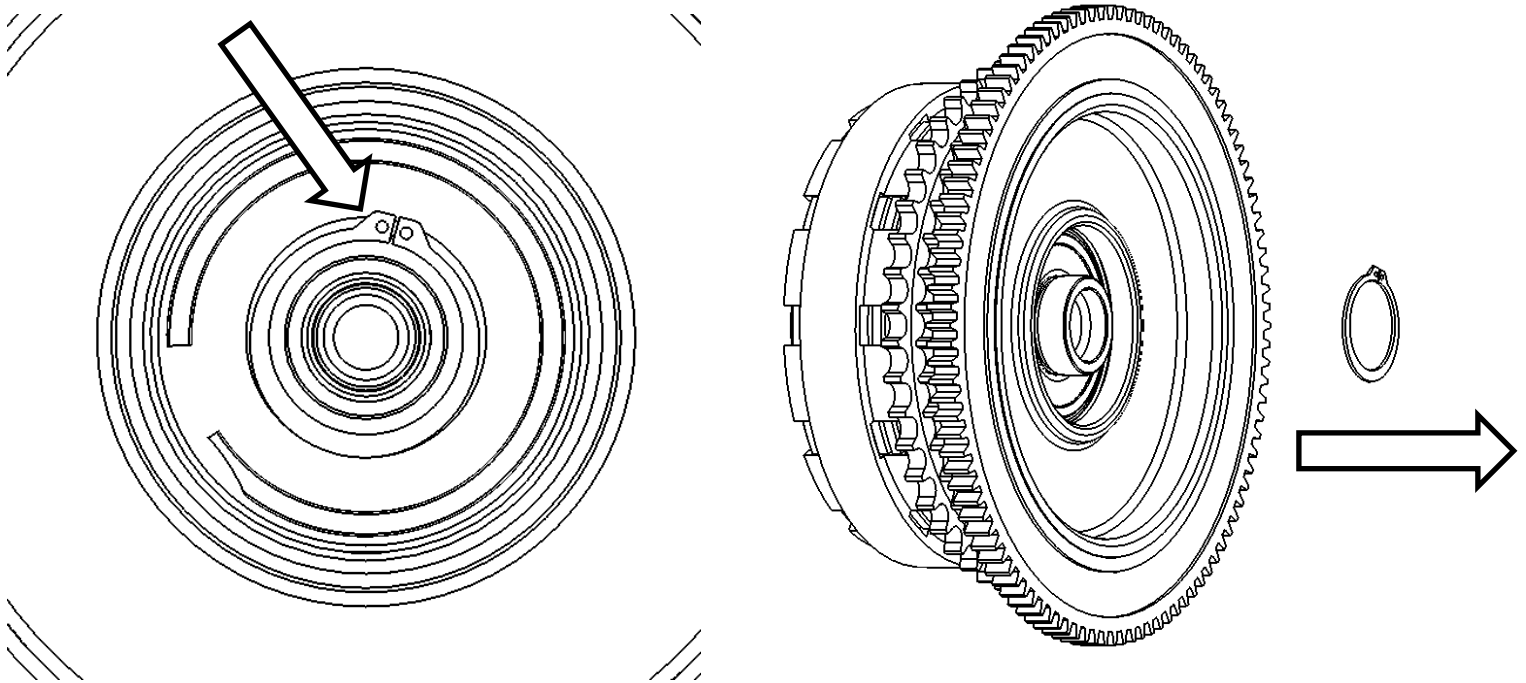

6. Using a hydraulic press, carefully press out the hub from the basket. Support the basket with something soft, such as wood to avoid damaging the basket.

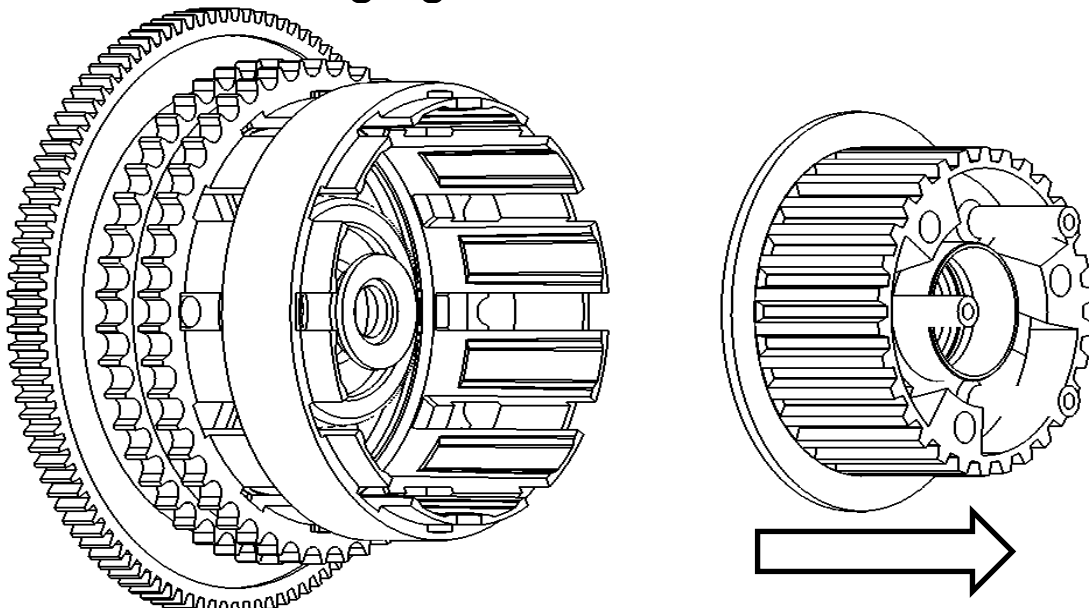

INSTALL THE REKLUSE HUB

1. Press the Rekluse hub into the basket. Do not press directly on the aluminum hub, only on the steel washer in the center.

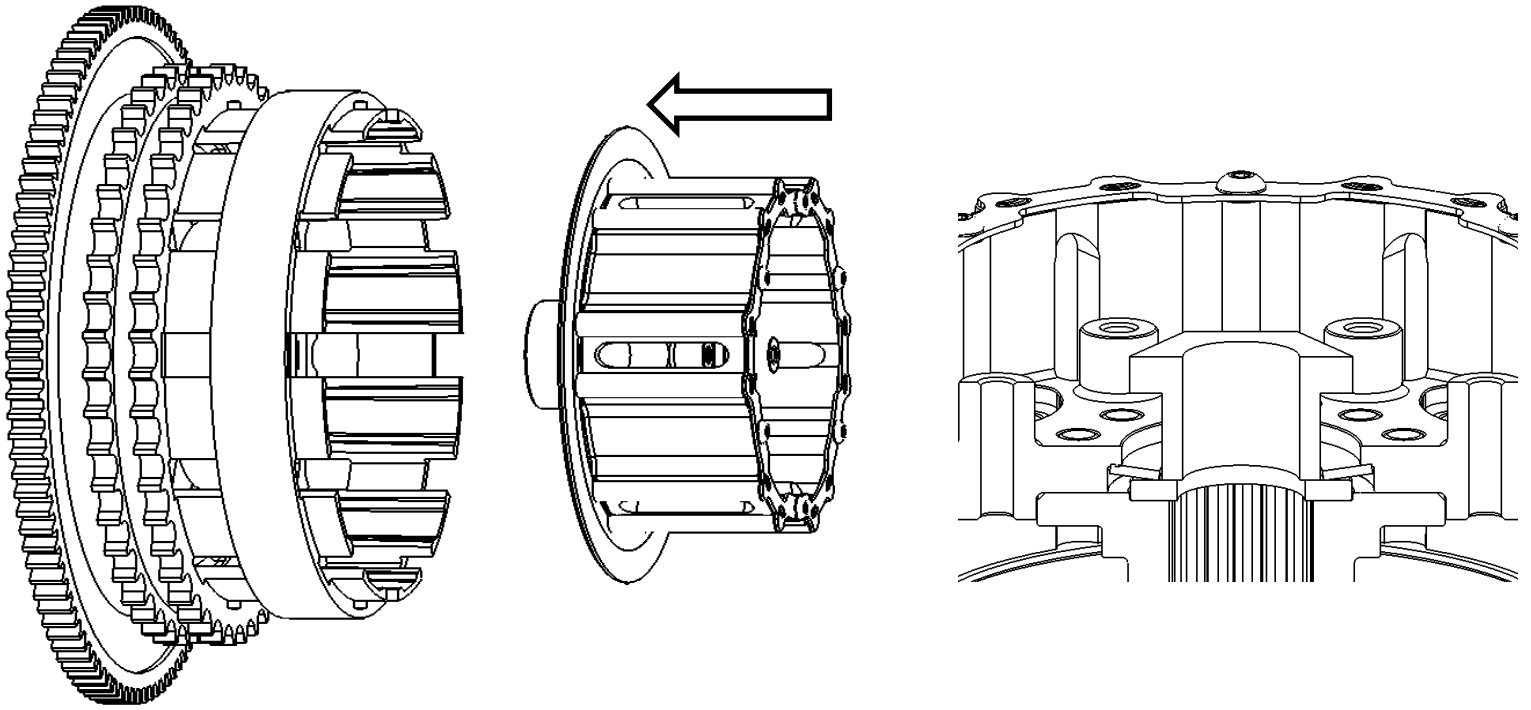

Note: It can be helpful to set the hub nut onto the hub when pressing it to give the press something to contact.

2. Install the OE snap ring onto the hub shaft

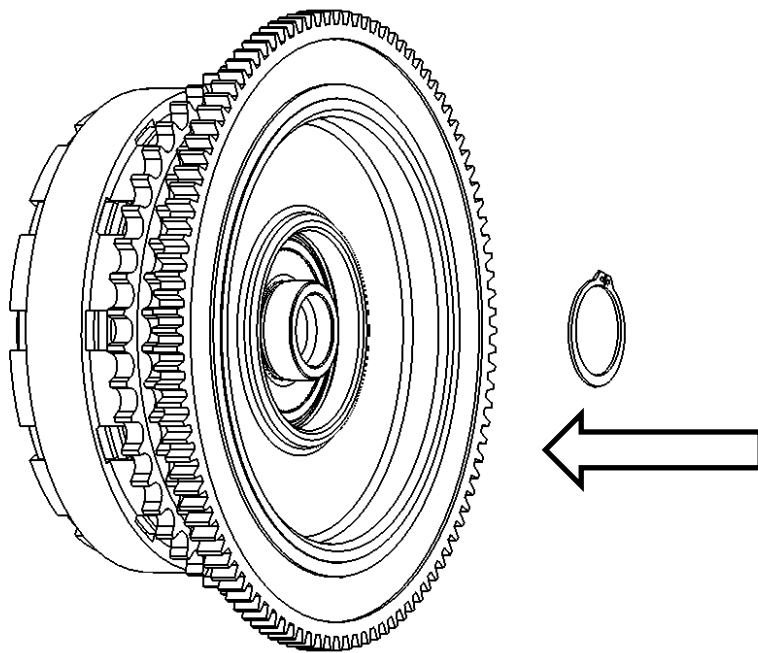

3. Reinstall the clutch hub & basket assembly onto the shaft along with the primary chain and the compensator sprocket

4. Apply two drops of the supplied Loctite to the compensator bolt and torque to **100 ft-lbs**, then back it off ½ turn and torque to **160 ft-lbs** for TwinCam models or **170 ft-lbs** for M8 models.
5. Apply two drops of the supplied Loctite to the **Left-hand thread** center hub nut and torque to **70-80 ft-lbs**.
6. Install the primary chain tensioner and torque to **21-24 ft-lbs**.

INSTALL THE BASKET SLEEVES

Install **ALL** the Rekluse basket sleeves into the OE basket slots. Make sure the sleeve tabs sit against the inside of the basket, then push the sleeves down until they contact the bottom of the tang slot.

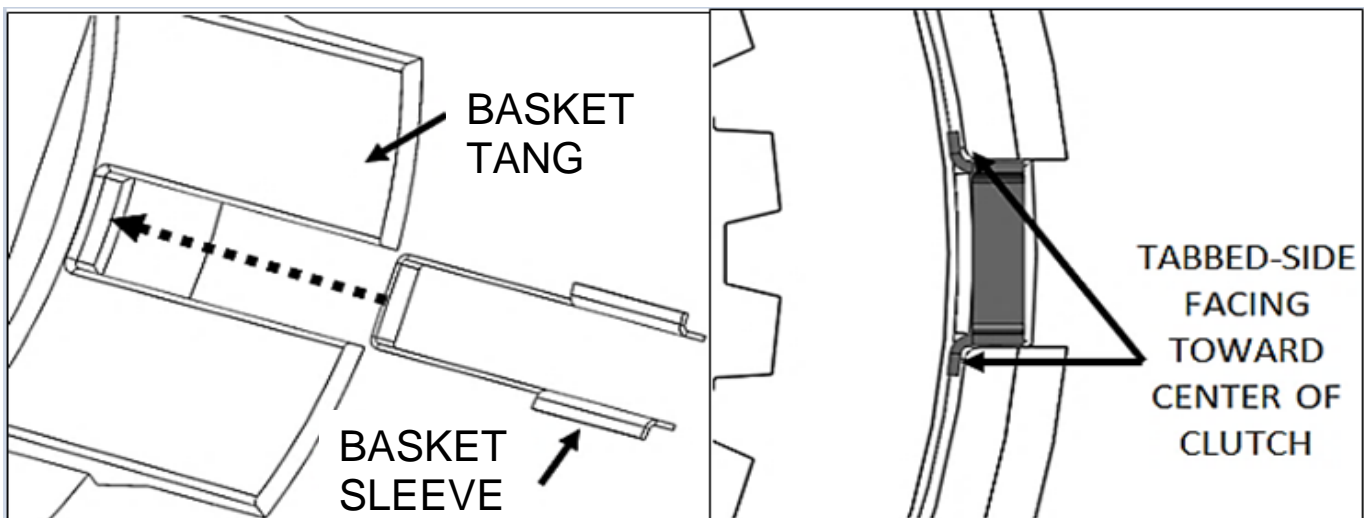

⚠ WARNING

Rekluse basket sleeves are designed to be installed into an OE or Rekluse clutch basket **ONLY**. The use of non-Rekluse aftermarket clutch baskets may cause clutch damage or failure.

INSTALL THE CLUTCH PACK

Refer to the included **Setup Sheet** for a breakdown of the clutch pack.

Note: Some friction disks are marked with a small colored dot. This mark is used for processing and can be ignored.

INSTALL THE PRESSURE PLATE

1. Remove the snap ring and bearing assembly from the OE pressure plate and install them into the Rekluse pressure plate. Ensure that the snapping seats properly into the groove.

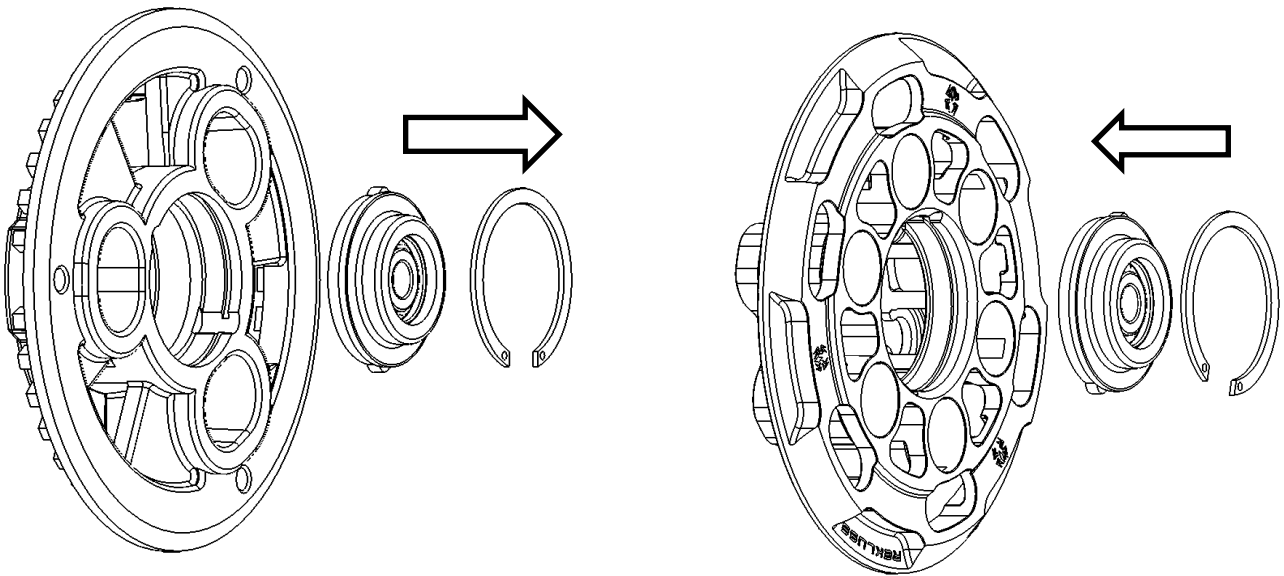

Note: The centerpiece may look different from the image above.

INSTALL THE CLUTCH SPRINGS

Select the desired springs from the tables below.

Milwaukee 8 Models (17+)

Note: The OE clutch is rated to hold approximately 125 ft-lbs of engine torque.

Torque Capacity (lb.ft)	Change in Lever Pull	Color
145	-20%	Silver
170	-5%	Silver and Red
200	+10%	Red

Twin Cam Models (07-16)

Torque Capacity (lb.ft)	Change in Lever Pull	Color
145	-34%	Silver
170	-22%	Silver and Red
200	-9%	Red

1. Install the Rekluse pressure plate springs, screw sleeves, and screws. Be sure to alternate springs if mixing colors.

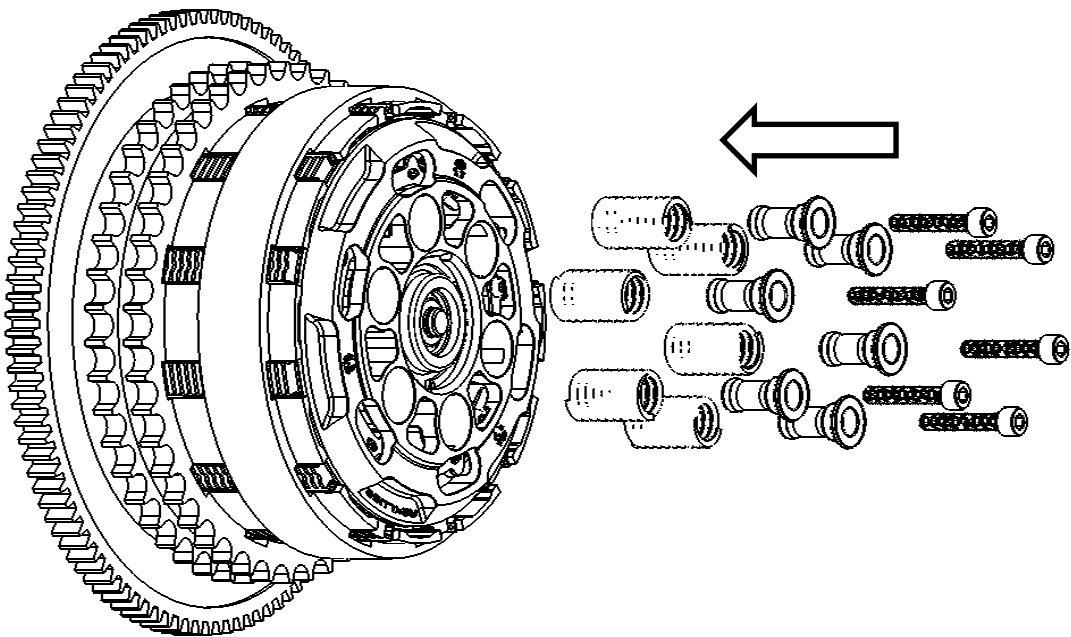

2. Torque the pressure plate screws to **9 lb-ft (12 N-m)**.

SET FREEPLAY (CABLE BIKES ONLY)

Cable-actuated bikes must set the proper lever freeplay. Hydraulic-actuated bikes skip to the next section.

Collapsing the Cable on an M8

1. Slide the black cover off the cable adjuster.
2. Unlock the red tab with a screwdriver.

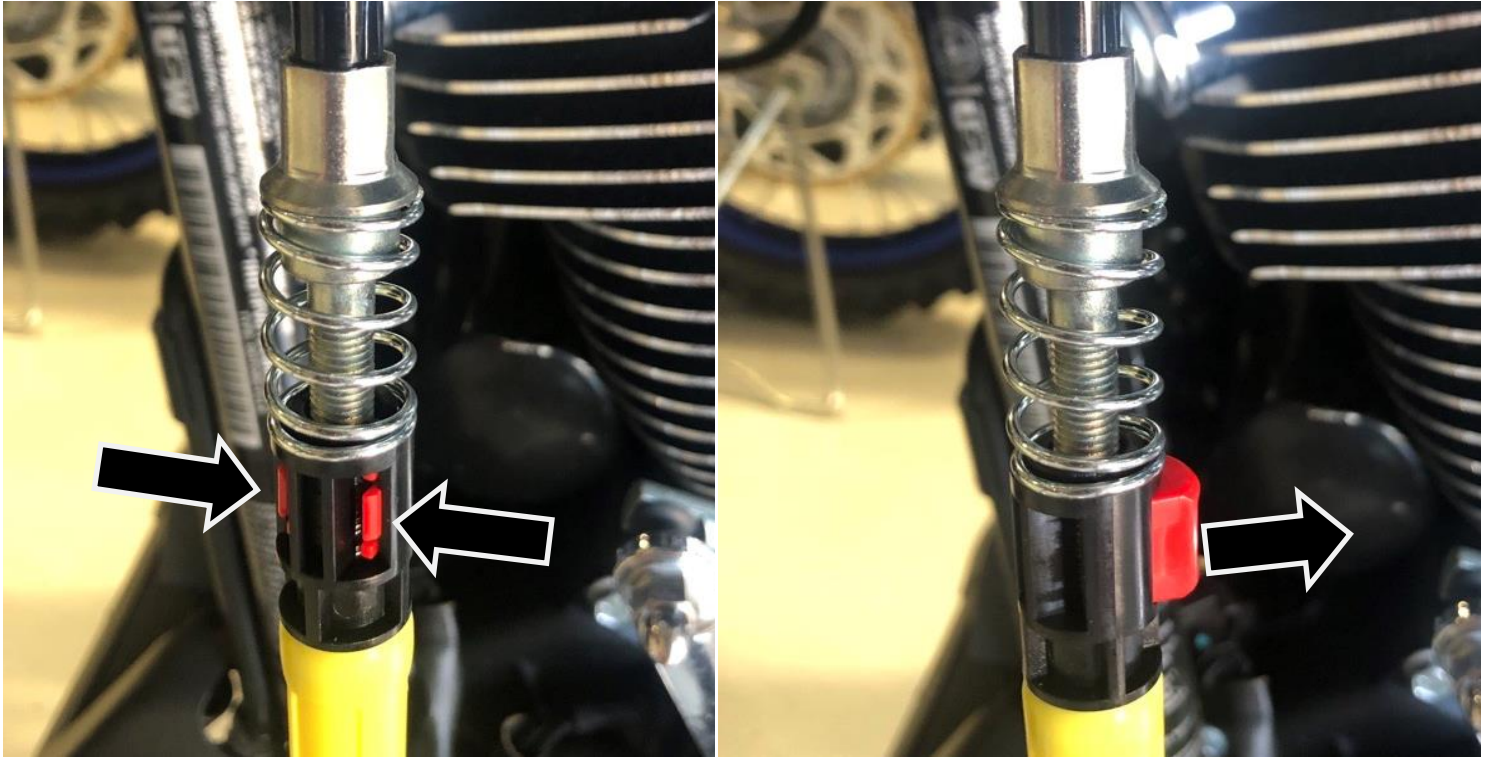

3. Compress the spring and relock the red tab to hold it.

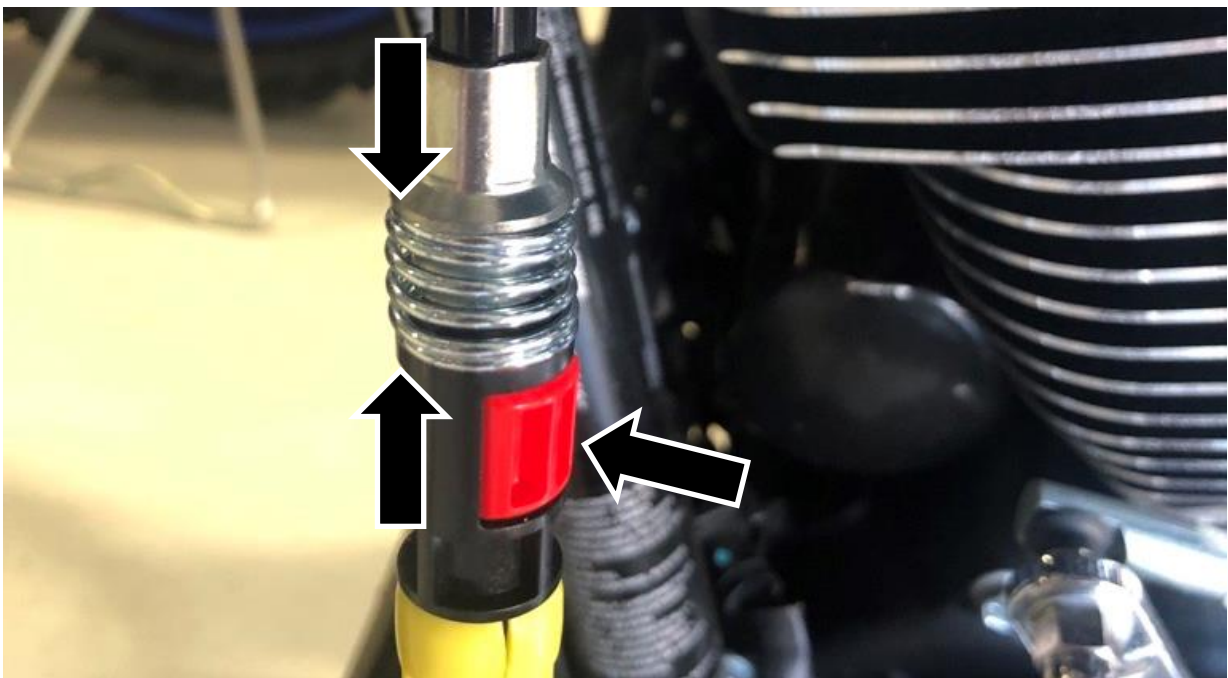

4. Check that the lever has a large amount of freeplay.

Collapsing the Cable on a Twin Cam

1. Loosen the jam nut on the inline cable adjuster
2. Collapse the inline cable adjuster completely
3. Check that the clutch lever has a large amount of free play. It should easily flop back and forth.

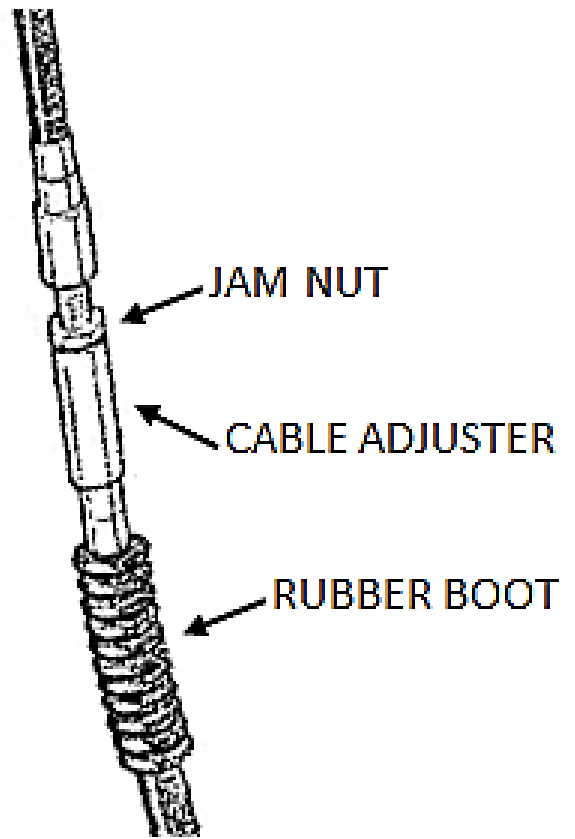

Set The Adjuster Screw

1. Loosen the jam nut

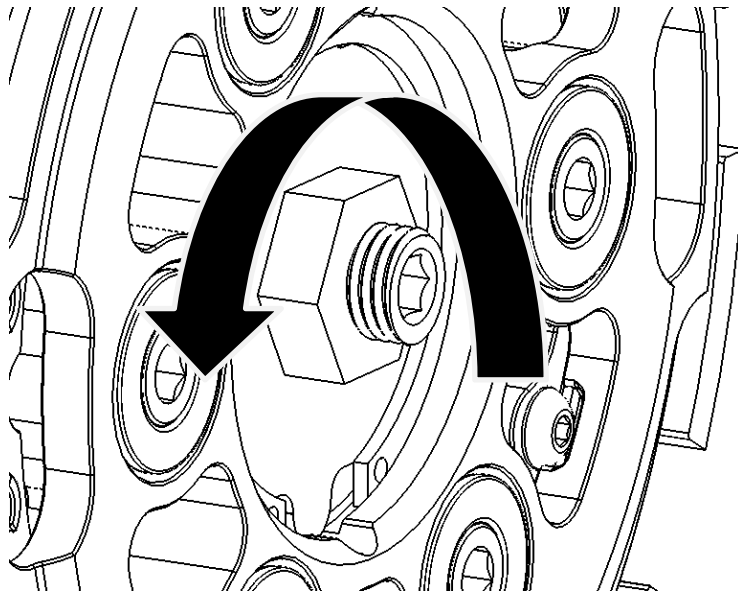

2. Turn the adjuster screw **COUNTERCLOCKWISE** until it spins freely

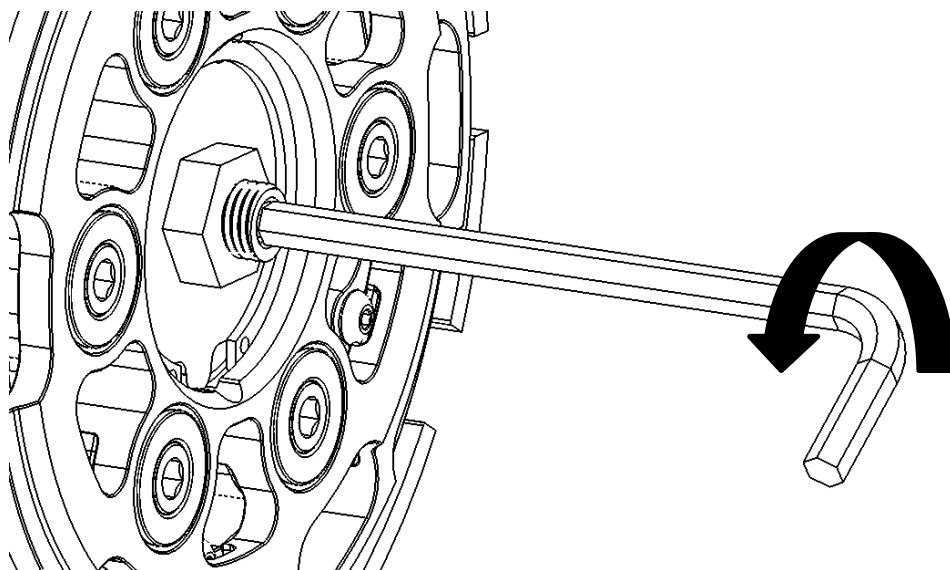

3. Next, gently turn the adjuster screw **CLOCKWISE** until it stops under moderate pressure.

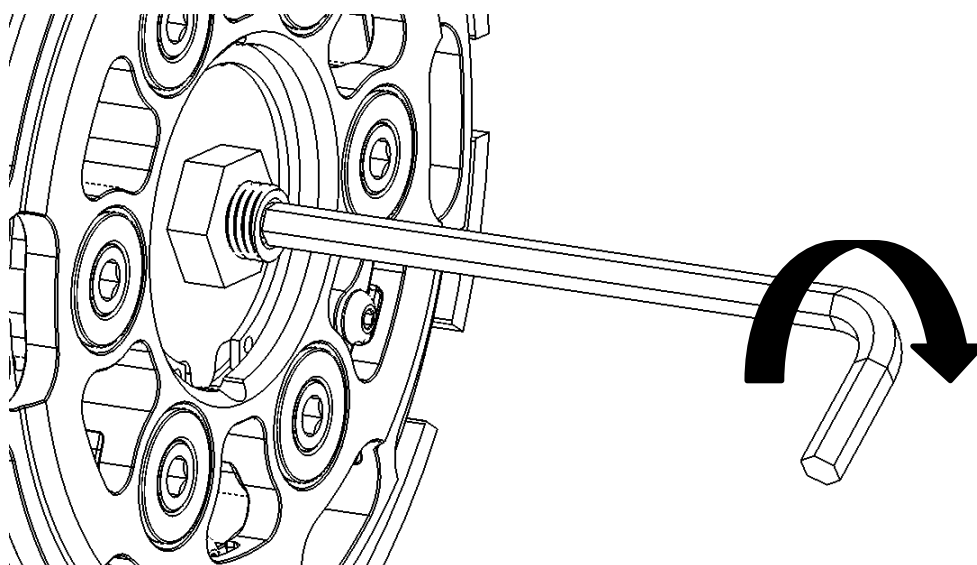

- You are feeling for the point at which the screw bottoms out and starts to lift the pressure plate. This position is called your **starting point**.

4. Once you have found the starting point, back off the adjuster screw $\frac{1}{2}$ turn **COUNTERCLOCKWISE** to set the freeplay.

5. While holding the adjuster screw from rotating, tighten the jam nut to lock it in place.

Resetting Cable Freeplay on an M8

1. Release the red tab on the cable adjuster so that the spring expands, then press the red tab to lock the adjuster in place.

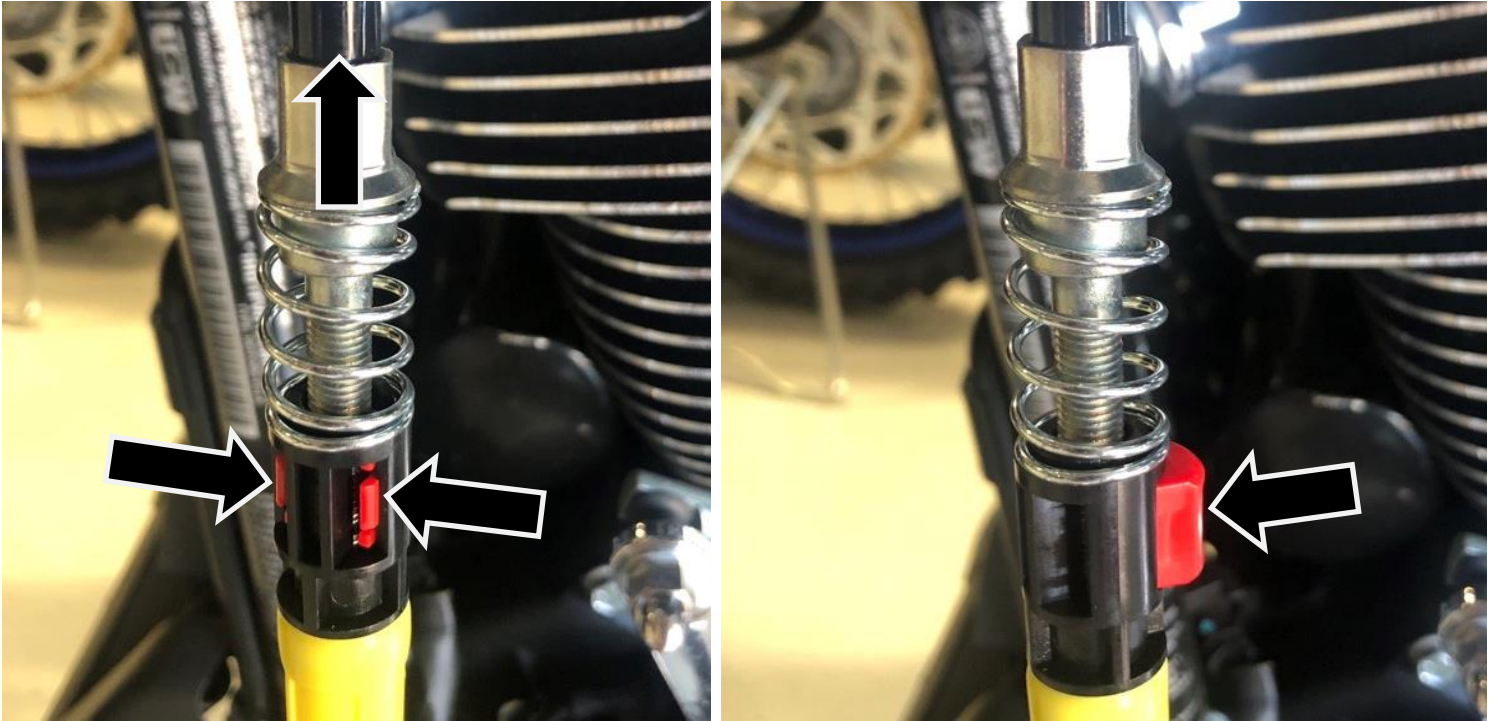

2. Check that the lever has the proper 1/16-1/8" of freeplay

Resetting Cable Freeplay on a TwinCam

1. Expand the in-line adjuster until the cable slack is between 1/16" and 1/8" at the lever perch.
2. Tighten the jam nut on the in-line adjuster

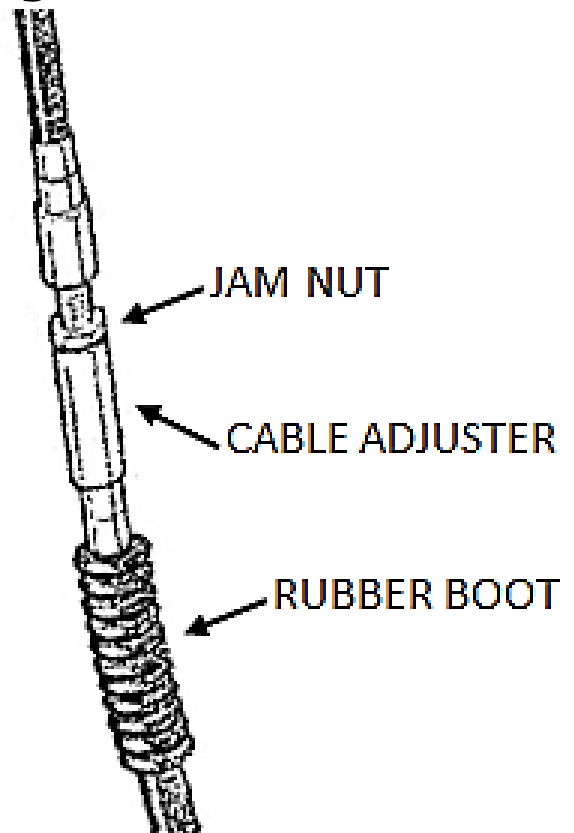

INSTALL THE PRIMARY COVER

1. Thoroughly clean the mating surfaces of the primary cover and the engine case.
2. Reinstall the primary gasket (or new gasket).
3. Reinstall the primary cover, then torque the cover bolts to **84-108 in-lb (9.5-12.2 N-m)**.
4. Reinstall the drain bolt, then torque the drain bolt to **36-60 in-lb (4-6.8 N-m)**.
5. With the primary cover installed, use a T-27 Torx bit to remove the derby cover.
6. Using a funnel, add 1 liter of appropriate oil to the primary case through the derby cover cavity.

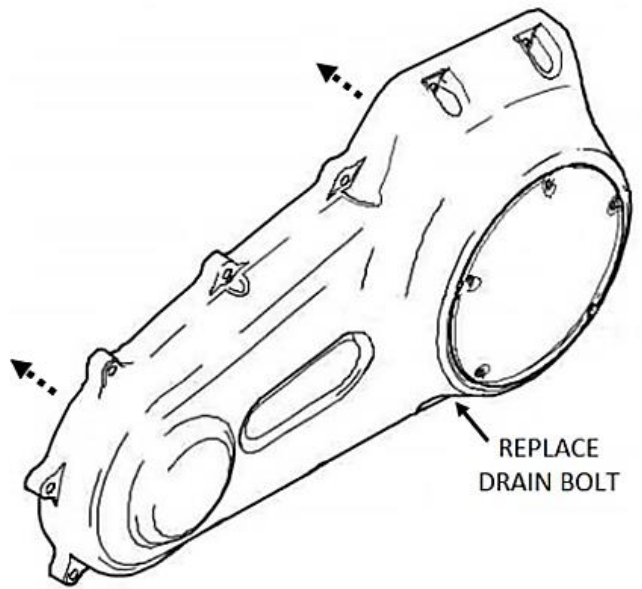

Rekluse offers **Factory Formulated Oil** specifically for the V-Twin primary.

7. Reinstall the derby cover and torque bolts to **84-108 in-lbs. (9.5-12.2 N-m)**.

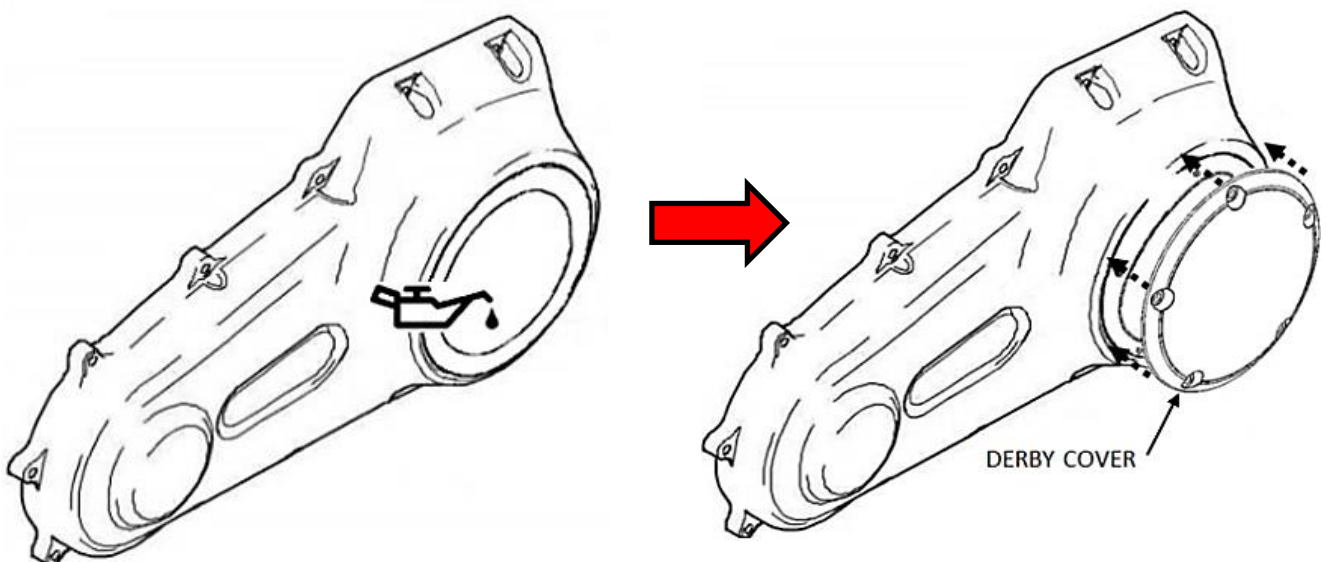

BREAK IN THE NEW CLUTCH

The clutch will break in within 100-200 miles of normal riding. Until the break-in is complete, you may experience more clutch drag than normal.

- It is recommended to do an oil change after the first 1,000 miles to drain any excess clutch debris that occurred from the break-in.

MAINTENANCE

To keep your clutch performing at its best, perform regular maintenance on your bike and clutch.

- Keep up with regular oil changes according to the bike manufacturer's recommendations. Clutch performance and longevity depend on oil quality. Tired, dirty, or worn oil may cause excessive clutch drag or noise.
- Use oil recommended by the manufacturer of your bike.
- For optimal clutch performance, Rekluse recommends using fresh, clean oil that **meets JASO-MA or MA2** standards.
- Inspect all of your clutch parts for signs of wear or excessive heat, and replace components as necessary. This includes your basket sleeves. Clutch wear is dependent on the rider's use.
- Replace friction disks if they measure below specifications or if the disks are glazed and/or burnt.
- Repeat the break-in procedure anytime you replace the friction disks. Always soak friction disks in oil for at least 5 minutes before installing.
- Replace the drive plates if they show signs of excessive heat.

Disk inspection examples

When inspecting the clutch pack, the following pictures can be used as a reference. **These are best viewed in color by viewing this install document on www.rekluse.com/support.**

Drive Plates – If the clutch pack is getting high amounts of heat, purple, blue, or black color can be seen on the drive plate teeth. See the pictures below. Not all drive plates look the same and may look different than pictured.



Normal Heat

High Heat
(Blue)

Excessive Heat
(Black)

Friction Disks – Due to the dark color of the friction material, the friction disks will appear almost black as soon as they are put in oil. During the inspection, look for glazing of the friction material. Glazing will appear shiny and feel like glass, even after the oil is cleaned from the friction disk. Not all friction disks look the same and may look different than pictured.



Normal Friction



Glazed Friction

TROUBLESHOOTING

Clutch Drag:

- Make sure the bike has reached operating temperature. Drag may occur when the engine is cold.
- For cable bikes: Check that the cable freeplay is set properly. Excessive freeplay may cause drag.
- Put in new Rekluse recommended oil. Old or improper oil can cause performance issues.
- Check the clutch pack for signs of excessive heat or warpage.

Clutch Slip:

- Inspect the clutch for signs of excessive heat.
- For cable bikes: Readjust the lever freeplay as described in this manual.
- If clutch slip persists, heavier clutch springs are recommended.

NEED ADDITIONAL HELP?

Website

www.rekluse.com/support

Phone

(208) 426-0659

Monday thru Friday: 8 am – 5 pm Mountain Time

Email

customerservice@rekluse.com



SETUP SHEET 198-7115005

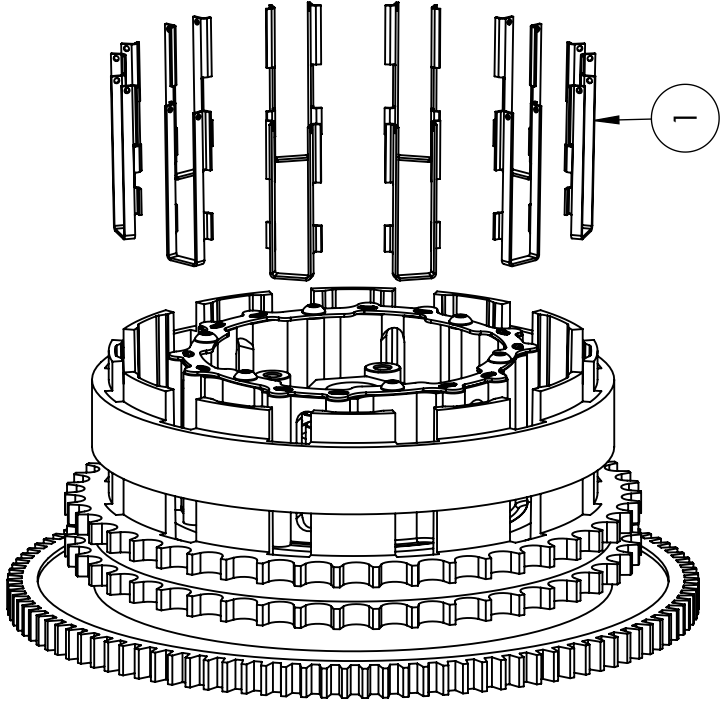
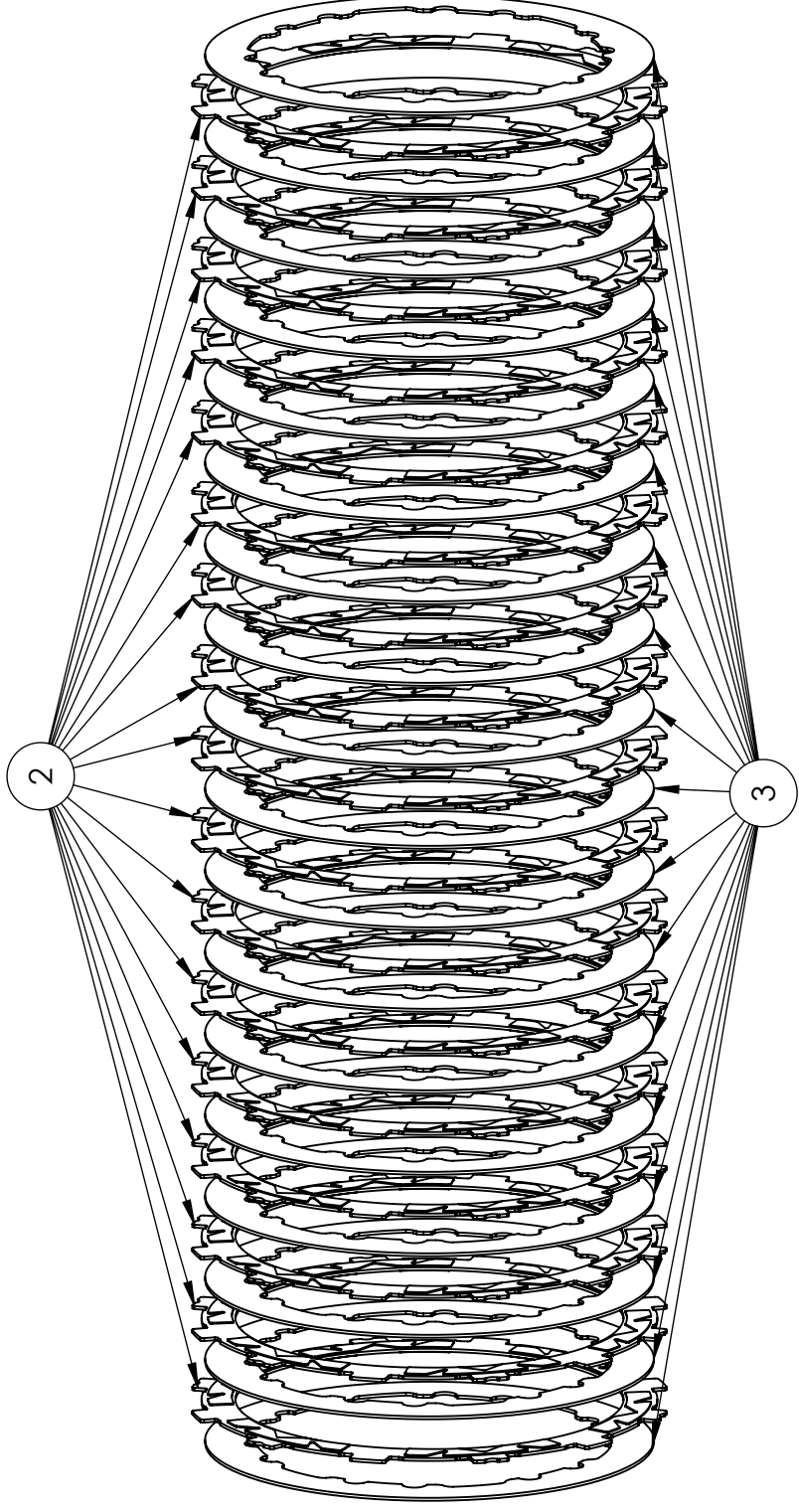

CLUTCH PACK THICKNESS

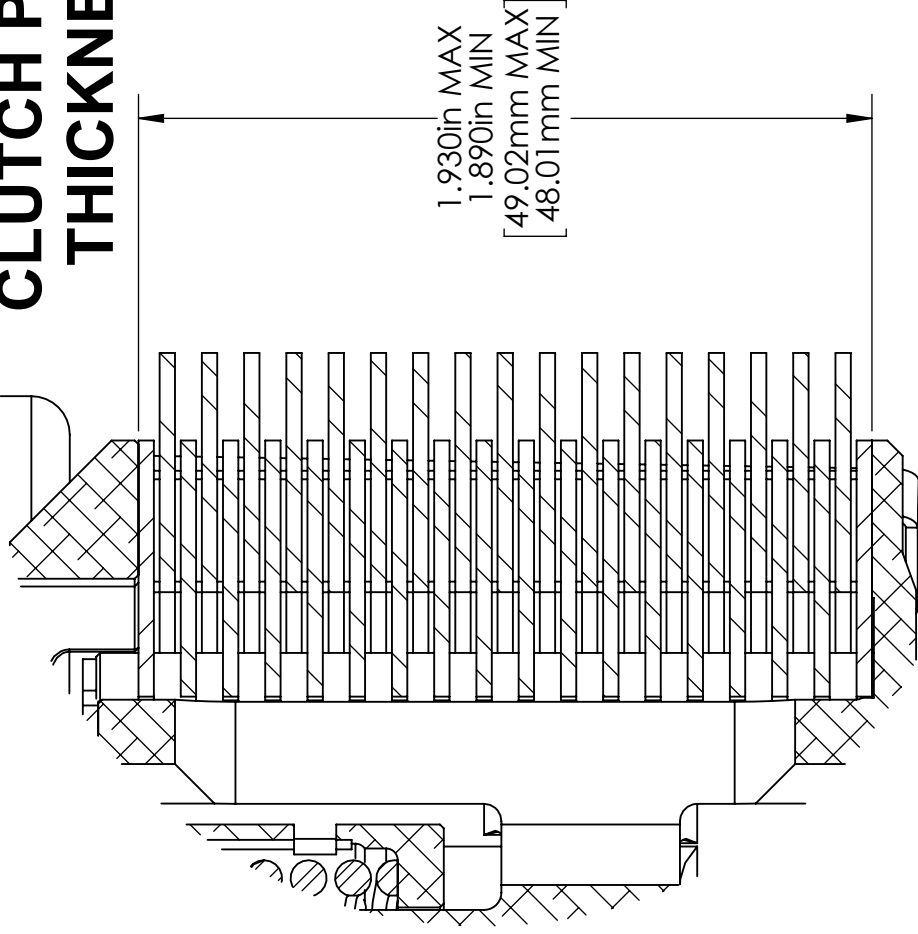

SERVICE LIMITS

COMPONENT	STANDARD	SERVICE LIMIT
TORQDRIVE FRICTION	.068-.072in 1.73-1.83mm	.065in 1.65mm

COMPONENTS

ITEM NO.	DESCRIPTION	QTY.
1	BASKET SLEEVES	12
2	TORQDRIVE FRICTION	17
3	DRIVE PLATE	18
4	PRESSURE PLATE	1
5	PRESSURE PLATE SPRINGS	6
6	SCREW SLEEVE	6
7	M6 SCREW	6
OE	OE COMPONENTS	VAR